

GENERAL CHARACTERISTICS



A wide range of standard units that, for variety of materials and dimensions, offers to the user a simple and economical solution for the control of liquid levels. The units are available with connection cable in lengths of 1.5 m and 3.0 m, other lengths are available on request.

The cable is sealed together with the contact inside the rod with epoxy resin and polymerization is performed in a controlled temperature oven.

The principle of operation of these instruments is based by actuation of a reed contact, located inside of the measuring rod, by a magnetic float.

The only moving element is the float, that moves as a result of hydrostatic thrust, this gives extreme ruggedness and limited need of maintenance to the system.



- Brass, AISI-316, PVC, Polypropylene, PVDF constructions
- Working pressure up to 50 bar, depending on the used float
- Operating ambient temperature -30/+55°C RH 90%.
- Executions for temperature up to 180 °C, on request.
- Minimum degree of protection IP65.

- ATEX construction 1G Exia IIC T6, see SIMPLE ATEX I

BRASS / SPANSIL SERIES

Tab.1



Float	Butadiene - Acrylonitrile Copolymer		
S.G.	0,4	0,35	0,45
Rod	Brass	Nickel plated brass	Brass
Bar max	20 bar		
°C max	105 °C = L Class		
Contact	3	3 - 7D	4 - 7
Cable	C1 = 1,5 m - C2 = 3,0 m		

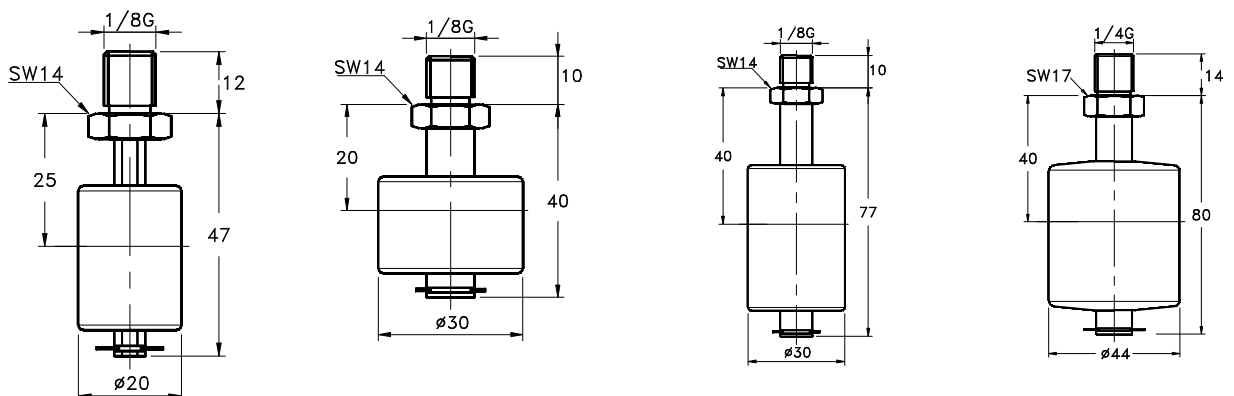

PLASTIC SERIES

Tab.2

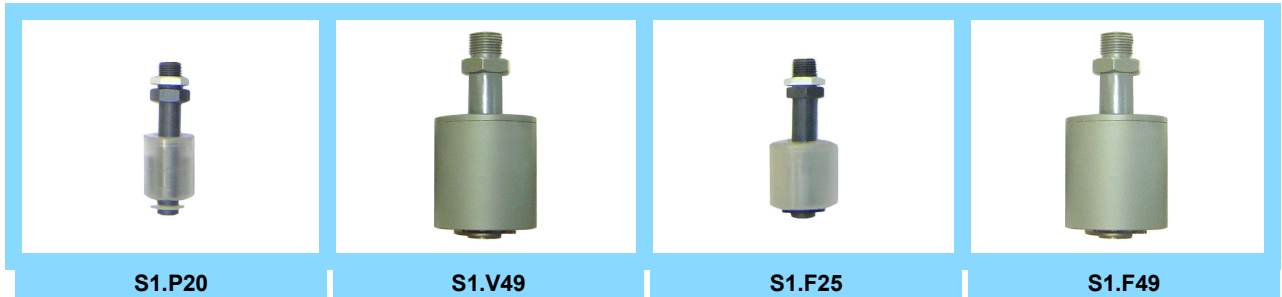

Float	Polypropylene	PVC	PVDF	
S.G.	0,5	0,7	0,65	0,8
Rod	PVC		PVDF	
Bar max	3 bar	6 bar	6 bar	
°C max	90 °C = D Class	60 °C = B Class	130 °C = N Class	
Contact	3	4 – 7	3	4 – 7
Cable	C1 = 1,5 m – C2 = 3,0 m			

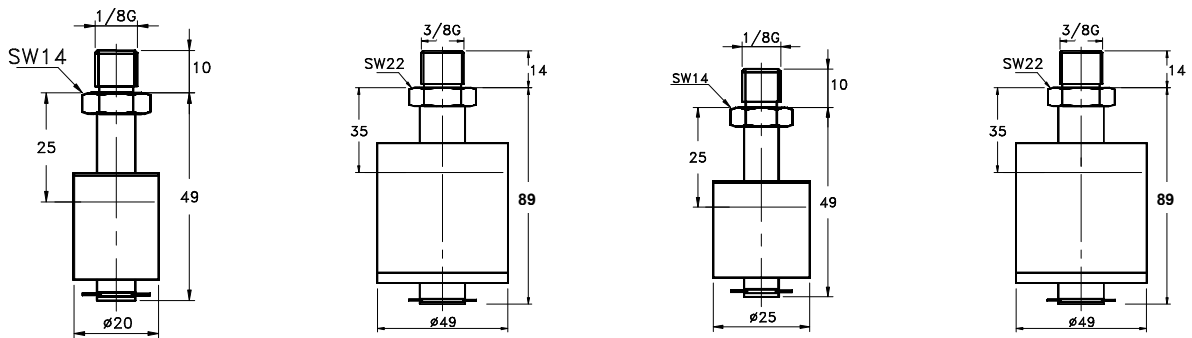

STAINLESS STEEL SERIES

Tab.3



Float	AISI – 316			
S.G.	0,75	0,65	0,7	0,6
Rod	AISI – 316			
Bar max	30 bar	10 bar	50 bar	15 bar
°C max	105 °C = L Class			
Contact	3 – 7D	4 – 7	7	
Cable	C1 = 1,5 m – C2 = 3,0 m			

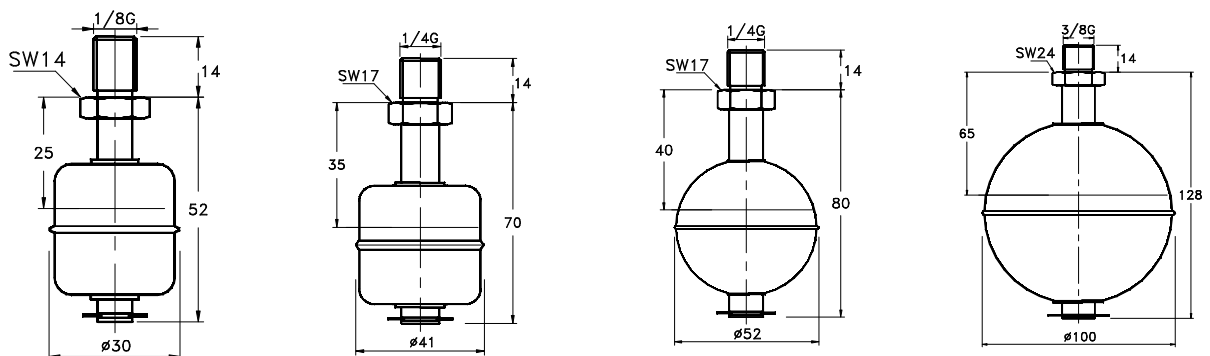

ELECTRICAL CONTACTS

Tab.4

TYPE		POWER		VOLTAGE		CURRENT	
		VA	W	AC	DC	AC	DC
3	SPST	70	50	300	350	0,5	0,7
4	SPST	80	80	250	250	1,3	1.3
7	SPDT	60	60	230	230	1	1
7D	SPDT	20	20	150	150	0,5	0,5

WIRING

Tab.5

I	Independent	Separately wired contact	2	NC	Contact status in no level condition
			1	NO (*)	
			3	SPDT	

(*) The NO condition is obtained by turning the float of 180°

DIMENSIONAL SUMMARY TABLE mm

Tab.6

S1	B20	B28	B44	B45	F25	P20	V49	F49	S29	S41	S52	S100
L0	40	47	80	77	49	49	82	82	52	70	80	128
L1	20	25	40	40	25	25	40	35	25	35	40	65
Ø	30	20	44	30	25	20	49	49	30	41	52	100
SW	14	14	17	14	14	14	22	22	14	17	17	24
B	10	12	14	10	10	10	14	14	14	14	14	14
A	1/8"	1/4"			1/8"			3/8"	1/8"		1/4"	3/8"
	06	08			06			10	06		08	10

L1 = switch-point with liquids of specific gravity = 1
Tolerance on the switch-point ± 3 mm.

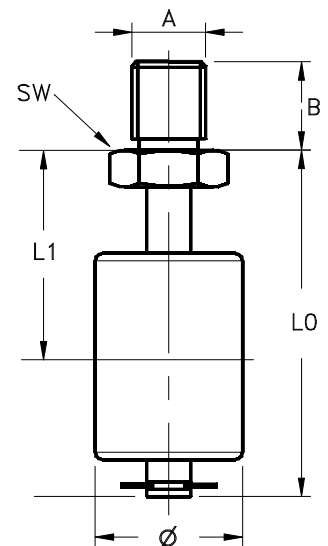

Male threads

G	C	N
Gas parallel UNI 228/1	Gas conical UNI 7/1	Conical NPT
On request		

Rod and process connection materials

B	O	S	V	F
Nickel plated brass	Brass	AISI-316	PVC	PVDF

NOMENCLATURE

S1	S52	4	0080	S	08	G	S	C1	L	I2	L1		
•												Tab.1 ÷ 3	Series and type
	•											Tab.1 ÷ 3	Electrical contact
		•										Tab.6	Total length = L0
			•									Tab.1 ÷ 3	Rod material
				•								Tab.6	Process connection dimension
					•							Tab.6	Process connection thread
						•						Tab.6	Process connection material
							•					Tab.1 ÷ 3	Electrical output – Cable length
								•				Tab.1 ÷ 3	Temperature class
									•			Tab.5	Wiring and contact status
										•		Tab.6	Switch-point